



Town of Hopkinton

330 Main Street • Hopkinton, New Hampshire 03229 • www.hopkinton-nh.gov

Tel: 603-746-3170

Fax: 603-746-3049

HOPKINTON ZONING BOARD OF ADJUSTMENT PUBLIC NOTICE – AGENDA MAY 10, 2018

Notice is hereby given that the Hopkinton Zoning Board of Adjustment will meet on Thursday, May 10, 2018, at 6:30 PM in the Hopkinton Town Hall, 330 Main Street, Hopkinton, NH, to review and take action on the following.

- I. **Call to Order** (Determine quorum, review attendance of Regular Members and seating of Alternate Members, if necessary).
 - II. **Applications.**

Summit Holdings, LLC (#2018-06) Special Exceptions for retail, closed storage and associated outside storage on property owned by Lisa Thorne on Maple Street in the M-1 (Industrial) district, TM/L 227-040-001. The application was submitted in accordance with Zoning Ordinance Table of Uses 3.6.F.1, 3.6.G.11 and 3.6.H.6.
 - III. **Any other business that may legally come before the Board.**
 - IV. **Adjournment** (Next regular meeting is Tuesday, June 5, 2018).
-



Town of Hopkinton

330 Main Street • Hopkinton, New Hampshire 03229 • www.hopkinton-nh.gov

Tel: 603-746-3170

Fax: 603-746-3049

HOPKINTON ZONING BOARD OF ADJUSTMENT PUBLIC NOTICE – AGENDA MAY 1, 2018

Notice is hereby given that the Hopkinton Zoning Board of Adjustment will meet on Tuesday, May 1, 2018, at 5:30 PM in the Hopkinton Town Hall, 330 Main Street, Hopkinton, NH, to review and take action on the following.

I. **Call to Order** (Determine quorum, review attendance of Regular Members and seating of Alternate Members, if necessary).

II. **Applications.**

Peter Grenier (#2018-05) Variance for multi-family dwelling units on property owned by River House Properties, LLC at 1966 Maple Street in the M-1 (Industrial) district, TM/L 210-018-000. The application was submitted in accordance with Zoning Ordinance Table of Uses 3.6.A.3.

✓ **Summit Holdings, LLC (#2018-06)** Special Exceptions for retail, closed storage and associated outside storage on property owned by Lisa Thorne on Maple Street in the M-1 (Industrial) district, TM/L 227-040-001. The application was submitted in accordance with Zoning Ordinance Table of Uses 3.6.F.1, 3.6.G.11 and 3.6.H.6.

III. **Review of Minutes and Notice of Decisions.**

- a) Minutes of March 6, 2018
- b) Notice of Decision of March 6, 2018
- c) Minutes of April 3, 2018

IV. **Any other business that may legally come before the Board.**

V. **Adjournment** (Next regular meeting is Tuesday, June 5, 2018).



Town of Hopkinton

330 Main Street • Hopkinton, New Hampshire 03229 • www.hopkinton-nh.gov

Tel: 603-746-3170

Fax: 603-746-3049

HOPKINTON ZONING BOARD OF ADJUSTMENT PUBLIC NOTICE – AGENDA APRIL 3, 2018

Notice is hereby given that the Hopkinton Zoning Board of Adjustment will meet on Tuesday, April 3, 2018, at 5:30 PM in the Hopkinton Town Hall, 330 Main Street, Hopkinton, NH, to review and take action on the following.

- I. **Call to Order (Determine quorum, review attendance of Regular Members and seating of Alternate Members, if necessary).**
 - II. **Applications.**
 - Peter Grenier (#2018-05)** Variance for multi-family dwelling units in the M-1 (Industrial) district. The property is owned by River House Properties, LLC, located at 1966 Maple Street, shown on Tax Map 210 as Lot 18. The application was submitted in accordance with Zoning Ordinance Table of Uses 3.6.A.3.
 - ✓ **Summit Holdings, LLC (#2018-06)** Special Exceptions for retail, closed storage and associated outside storage on property located in the M-1 (Industrial) district. The property is owned by Lisa Thorne, located off Maple Street, shown on Tax Map 227 as Lot 40.1. The application was submitted in accordance with Zoning Ordinance Table of Uses 3.6.F.1, 3.6.G.11 and 3.6.H.6.
 - III. **Review of Minutes and Notice of Decision of March 6, 2018.**
 - IV. **Any other business that may legally come before the Board.**
 - V. **Adjournment (Next regular meeting is Tuesday, May 1, 2018).**
-

Town of Hopkinton, New Hampshire
Zoning Board of Adjustment
330 Main Street, Hopkinton, NH 03229
Tel: (603) 746-4487 · Fax (603) 746-2952
e-mail: planzone@hopkinton-nh.gov

HOPKINTON ZONING BOARD OF ADJUSTMENT
APPLICATION FOR APPEAL

Name of Applicant: Summit Holdings LLC

Mailing Address: 43 Bear Hill Road, Washington, N.H. 03280

Telephone (days): (603) 495-1821

Name of Property Owner: Lisa Thorne

Mailing Address: 519 Maple Street, Contoocook, N.H. 03229

Telephone (days): (603) 746-1086

Tax Map: 227 Lot: 40-1 (Pending) Location of Property: 519? Maple Street (Address Pending)

Zoning of property in question (circle one): R-1 R-2 R-3 R-4 B-1 M-1 VR-1 VB-1 VM-1

Section of Hopkinton Zoning Ordinance under which your application was denied or you believe your proposal relates to: Section: III Paragraph/Table: Table 3.6

A copy of your denied Building/Use Application or administrative decision must be attached.

This application is for: Variance Special Exception Equitable Waiver Administrative Appeal

The undersigned hereby requests a Variance, Special Exception, Equitable Waiver, and Administrative Appeal in order to permit the following:

To permit the following uses for a proposed 5 unit building on the subject property:

3.6.F.1 - Retail Establishment

3.6.F.2 - Business Offices Permitted (RP)

3.6.G.11 - Closed Storage of Raw Materials, Finished Goods or Construction Equipment

3.6.H.6 - Outside Storage Necessary for the Operation and Conduct, of a Permitted Principal

Wholesale, Transportation, Industrial and/or Commercial Use.

NOTE: This application is not acceptable unless all required statements have been completed.
Additional information may be supplied on a separate sheet if the space provided is inadequate.

1. Hearing, Abutter, Notification Fees:

- Variance – \$100.00
- Special Exception – \$100.00
- Equitable Waiver – \$100.00
- Administrative Appeal – \$100.00
- Rehearing – \$100.00
- Notification of each Owner, Applicant, Agent, Abutter – \$5.00
- Published Notice – \$75.00

2. List of names and mailing addresses of all abutters to the property as defined by NH RSA 672:3. Supply information on separate sheet. Abutter is any person whose property adjoins or is directly across the street or stream from the land under consideration.

3. Attach location map showing exact location of property in relation to at least one prominent landmark (road junction, business, town building, etc.). Include north arrow and label road names. Indicate with an X the location of the property in question.

4. **Attach site plan of property showing:** Boundaries and area of parcel; north point, scale and legend; location, size and type of all existing and proposed buildings, uses, parking, signs, roadways, screening, etc.
5. **List provisions to be made for septic disposal, fire protection, water supply, parking, noise, smoke, surface drainage, etc.** Supply information on separate sheet.
6. **Letter of Authorization to allow an Agent or Attorney to represent Applicant, if applicable.**
7. **Copy of property deed of the subject property.**
8. **Any other pertinent information that you feel the Board may need to assist in their decision making process.**

You must appear at the public hearing or be presented by an authorized agent or attorney for the Board to take action on your application. The application will be terminated or tabled for failure to appear at a scheduled public hearing, without first providing written notification to the Planning Department.

You are fully responsible for researching and knowing any and all laws, which may be applicable and affect the outcome of the Board's decision on your application request. The Town of Hopkinton assumes no responsibility or liability relating to your failure to research and know all applicable laws including, but not limited to, state, federal and local laws, codes, land development regulations and comprehensive plan. The Town of Hopkinton strongly encourages all applicants to consider consulting an attorney regarding their application.



You are encouraged to review the attached Rules of Procedures used by the Board of Adjustment at the public hearing.

I/we being duly sworn, depose and say that I am/We are the owner(s)/lessee(s) of land included in the application and that the foregoing statements herein contained and attached, and information or attached exhibits thoroughly to the best of my/our ability represent the arguments on behalf of the application herewith submitted and that the statements and attached exhibits referred to are in all respect true and correct to the best of my/or knowledge and belief.

In addition, I/We understand this application must be filed with all pertinent information as it pertains to the requirements of the Town of Hopkinton Zoning Ordinance and all other information requested or required by the Zoning Board of Adjustment in order to be considered complete. I/We understand that this application will not be filed until all required information has been received, and do further understand that the Town of Hopkinton reserves the right to postpone this request until such time as the requirements are met.

Furthermore, I/We understand that I/We, our representative as stated on the application, should appear at the public hearing. If photographs, documents, maps or other materials are provided to the Board as evidence at the public hearing, said evidence will become property of the Town of Hopkinton and will remain on file for future reference.

Also, I/We recognize and understand that the public hearing before the Board of Adjustment regarding land development is considered quasi-judicial in nature. **State and local law strictly prohibits applicants and/or interested parties from participating in ex-parte communications with Board members in person, by phone, e-mail, or in writing before the application is discussed at a public hearing.**

Applicant's Signature: <u></u>	Date: <u>3-19-18</u>
Applicant's Printed Name: <u>ANTHONY COSTELLO</u>	Date: <u>3-19-18</u>
Owner's Signature: <u></u>	Date: <u>3/19/18</u>
Owner's Printed Name: <u>LISA A THORNE</u>	Date: <u>3/19/18</u>

SPECIAL EXCEPTION
(Section XV)

In order to secure a variance, the Zoning Board of Adjustment must determine by law that your Special Exception request satisfies the following criteria of the Zoning Ordinance. **Please provide a written response along with any other supporting documentation for each of the following criteria.** Please note that all criteria must be satisfied and supported by the Zoning Board of Adjustment in order for a Special Exception to be granted. Should the space provided be inadequate, please attach additional pages to this application.

1. Standards provided by this Ordinance for the particular use permitted by special exception.

3.6.F.1 - Retail Establishment, 3.6.F.2 - Business Offices, 3.6.G.11 - Closed Storage of Raw Materials, Finished Goods or Construction Equipment, 3.6.H.6 - Accessory Building for Storage or Outside Storage Necessary for the Operation and Conduct, of a Permitted Principal Wholesale, Transportation, Industrial and/or Commercial Use.

2. No hazard to the public or adjacent property on account of potential fire, explosion or release of toxic materials.

The proposed use will not create a hazard to the public or adjacent property on account of fire, explosion or release of toxic materials. No toxic materials will be stored on-site. The nearest dwelling is over 100 feet away. We will add fire suppression if required by the Board.

3. No detriment to property values in the vicinity or change in the essential characteristics of a residential neighborhood on account of the location or scale of buildings and other structures, parking areas, access ways, odor(s), smoke, gas, dust, or other pollutant, noise, glare, heat, vibration, or unsightly outdoor storage of equipment, vehicles or other materials.

The proposed use, building, parking, etc. is consistent with other uses permitted in the Industrial Zone. The proposed building will be used to house/rent to service type businesses. There will not be any manufacturing or processing of goods.

4. No creation of a traffic safety hazard or a substantial increase in the level of traffic congestion in the vicinity.

The proposed use will not generate a substantial increase in traffic.

5. No excessive demand on municipal services, including, but not limited to, water, sewer, waste disposal, police and fire protection, and schools.

The proposed building will be serviced by on-site septic and well. There will not be any excessive demands on the police or fire departments and there will be no demands on the school.

6. No significant increase of storm water runoff onto adjacent property or streets.

Storm water runoff will be controlled on-site to prevent increases to adjacent property or streets.

7. An appropriate location for the proposed use.

The property is located away from the center of Contoocook and near Interstate 89 Exit 6 near existing commercial and industrial properties. The zoning in this area was recently changed to allow these uses.

8. Not affect adversely the health and safety of the residents and others in the area and not be detrimental to the use or development of adjacent or neighboring properties.

The proposed use will not adversely affect the health and safety of the residents nor will it be detrimental to the use or development of adjacent properties.

9. In the public interest and in the spirit of the ordinance.

This property was recently re-zoned to an Industrial Zone. This use is consistent with the spirit of the zoning ordinance and public interest.

KR

**SECTION II
DEFINITIONS**

2.1.F.3 Frontage: The horizontal distance measured along a lot line dividing a lot from a street. Driveways to rear lots shall not be construed as frontage.

2.1.H.1 Home Business: Shall mean any business or profession conducted entirely within a dwelling, or an accessory building located on the same premises as the dwelling, which (a) entails contact with the general public at the premises, (b) is capable of being unobtrusively pursued, (c) creates no nuisance nor any environmental, health or safety concerns, (d) is clearly incidental and subordinate to the dwelling use, (e) does not change either the character of the dwelling as a residence or the character of the neighborhood in which the Home Business is established, (f) is conducted by the resident owner(s) of the dwelling, (g) employs not more than one person outside the Family (as defined in Section II, Paragraph 2.1.F.1), and (h) utilizes an area (either in the dwelling or in an accessory building) of not more than twenty-five percent (25%) of the total floor area of the dwelling (including any functional basement) or five hundred (500) square feet, whichever is less. A Home Business shall be subject to the provisions of Section III, Paragraph 3.7.3 of this Ordinance.

2.1.H.2 Home Occupation: Shall mean any individual business or profession conducted entirely within a dwelling which (a) entails no contact with the general public at the dwelling (except normal postal and commercial delivery services), (b) is capable of being unobtrusively pursued, (c) creates no nuisance nor any environmental, health or safety concerns, (d) is clearly incidental and subordinate to the dwelling use, (e) does not change either the character of the dwelling as a residence or the character of the neighborhood in which the Home Occupation is established, (f) is conducted solely by the resident owner(s) of the dwelling, and (g) utilize an area of not more than twenty-five percent (25%) of the total floor area of the dwelling (including any functional basement) or 500 square feet, whichever is less. Home Occupations shall be subject to the provisions of Section III, Paragraph 3.7.5 of this Ordinance.

2.1.H.3 Hospital: A building providing 24-hour in-patient services for the diagnosis, treatment, or other care of human ailments including a sanitarium, clinic, rest home, nursing home, and convalescent home.

2.1.H.4 Hotel: Any building, or any part thereof, which contains one or more Lodging Units devoted to transient or semi-transient rental occupancy and which has a common entrance or entrances, including an inn, motel, motor inn, tourist court, boarding house, lodging house or rooming house, but specifically excepting a Bed and Breakfast Home and Bed and Breakfast Inn.

2.1.H.5 Housing for the Elderly: A building or group of buildings containing dwellings where the occupancy of the dwellings is restricted to persons 60 years of age or older or couples where either the husband or wife is 60 years of age or older. This does not include life care or nursing home facilities.

* **2.1.I.1 Industrial Use:** Any activity that entails manufacturing, processing, assembling, warehousing storage, distribution, shipping and/or other related uses. For the purpose of this definition, agricultural uses, home businesses, and home occupations, as defined in this Ordinance, shall not be considered industrial uses.

2.1.J.1 Junk: Old or scrap copper, brass, rope rages, batteries, paper, trash, rubber, debris, waste, or junked, dismantled, or wrecked automobiles, or parts thereof iron, steel and other old or scrap ferrous or nonferrous materials.

KR

SECTION II DEFINITIONS

2.1.R.3 Repair: Replacement or mending of parts already existing but in a state of deterioration with equivalent materials and for the purpose of maintaining their quality.

2.1.R.4 Restaurant: The term includes diners, cafes, and cafeterias and does not include *drive-in eating establishments*. It shall be an eating establishment which is primarily designed for its patrons to eat at tables, booths or a counter. Take-out refreshments are only incidental to the main purpose of the establishment.

* **2.1.R.5 Retail Establishment:** A place of business, including a discount and limited price variety store, selling convenience goods and general merchandise, including but not limited to foods, pharmaceutical drugs, proprietary goods, dry goods and apparel and accessories, furniture and home furnishings, home equipment, small wares and hardware.

2.1.R.6 Right-of-way (Public): All town, state and federal highways and the land on either side as covered by statutes to determine the widths of the right-of-ways.

2.1.S.1 Satellite Dish and Antenna: An accessory structure used for receiving television signals which must be so located on the lot that it is at least ten (10) feet from side and rear lot lines and has the same distance back from the front lot line as is required for the principal use in the district in which it is located.

2.1.S.2 School: An institution for instruction of children and/or adults in a formal setting with a prescribed curriculum and certified teachers.

2.1.S.3 Self-Service Storage Facility: A building or group of buildings that contains varying sizes of individual, compartmentalized, and controlled access stalls or lockers for the storage of customer's goods or wares.

2.1.S.4 Setback, Front: The distance extending across the full width of a lot between the front lot line and the front edge of a building or any projection thereof. See Figure titled "Setbacks Graphic" for more detail.

2.1.S.5 Setback, Rear: The distance extending across the full width of a lot between the rear lot line and the rear edge of a building or any projection thereof. See figure titled "Setbacks Graphic" for more detail.

2.1.S.6 Setback, Side: The distance between a side lot line and the side edge of building or any portion thereof. See figure titled "Setbacks Graphic" for more detail.

KR

SECTION II DEFINITIONS

2.1.S.10 Street: A way which is over twenty (20) feet in right-of-way width which is dedicated or devoted to public use by legal mapping or by any other lawful procedure.

2.1.S.11 Structure: A combination of materials assembled at a fixed location to give support or shelter, such as a building, bridge, trestle, tower, framework, retaining wall, tank, tunnel, tent, stadium, reviewing stand, platform, bin, sign, flagpole or the like.

2.1.S.12 Structure, Nonconforming: A structure lawfully existing at the effective date of this Ordinance or any subsequent amendment thereto, which does not conform to one or more provisions of this Ordinance.

2.1.S.13 Structural Alterations: Any change in the supporting members of a building or structure, such as load bearing walls, columns, beams or girders.

2.1.S.14 Subdivision: The division of a lot, tract, or parcel of land into two (2) or more lots, plats, sites or other division of land for the purpose, whether immediate or future, of sale, rent, lease, condominium conveyance, or building development. It includes re-subdivision, and where appropriate to the context, relates to the process of subdividing or to the land or territory subdivided. The division of a parcel of land held in common and subsequently divided into parts among several owners shall be deemed a subdivision under this title, per RSA 672:14.

2.1.T.1 Telecommuting: Shall mean the use of a dwelling by the resident owner(s) thereof for the purpose of providing services for communicating with such owner(s)' off-premises business employer by means of telecommunication facilities, including without limitation, facsimile, modern, and/or telephone, and through postal and light commercial delivery services. Other means of communication and delivery service shall not be permitted in connection with this use unless the resident owner(s) otherwise satisfy the requirements of this Ordinance for such manner of communication and delivery service. Telecommuting shall be subject to the provisions of Section III, Paragraph 3.7.5 of this Ordinance.

2.1.U.1 Use: The purpose for which a structure or lot is arranged, designed, or intended to be used, occupied or maintained.

* **2.1.U.2 Use, Accessory:** A use incidental and subordinate to the principal use of a structure or lot, or a use, not the principal use, which is located on the same lot as the principal structure. Accessory use by area shall be interpreted not to exceed forty (40) percent of the area of the total use of the structure and/or lot on which it is located.

2.1.U.3 Use, Adult: Shall mean a business where more than ten (10) percent of the gross revenues, ten (10) percent or more of the stock in trade, or ten (10) percent or more of the goods or paraphernalia displayed are of a sexually oriented or sexually explicit nature. Such goods and paraphernalia include, but are not limited to sexually oriented or sexually explicit materials. Examples of adult uses include, but are not limited to, theaters or mini-motion picture displays where sexually explicit materials are shown, nude modeling studios, sexually oriented massage parlors, escort agencies or sexually encounter centers. As used in this Ordinance, materials shall have the meaning set forth in RSA 650:1, III, or successor statute.

2.1.U.4 Use, Non-conforming: Non-conforming means use of land, building or premise which is not a use permitted by the provisions of this Ordinance for the district in which such land, building or premise is situated.

24

SECTION II DEFINITIONS

2.1.B.7 Building Height: The vertical distance measured from the average level of the grade at the building line to the highest point of the roof, excluding chimneys, ventilators, and other accessory features required above the roof.

2.1.B.8 Building Inspector: The Board of Selectmen or their designated representative.

2.1.B.9 Building Principal: A building in which is conducted the principal use of the lot on which it is located.

* **2.1.B.10 Business Offices:** Offices for uses such as insurance, computer consultants, various types of consultants, general businesses, and other offices which are not considered as falling within the definition of professional offices.

2.1.C.1 Cellar: A basement.

2.1.C.2 Certificate of Occupancy: A statement signed by the Building Inspector setting forth either that a building or a structure complies with this Ordinance or that a building, structure or parcel of land may lawfully be employed for specified uses or both.

2.1.C.2.a Certified Soil Scientist: A person who is currently certified or licensed by the State of New Hampshire under RSA 310-A:76 to identify, classify and to prepare high intensity soil maps.

2.1.C.2.b Certified Wetland Scientist: A person who is currently certified or licensed by the State of New Hampshire under RSA 310-A:76 to delineate wetland boundaries and prepare wetland maps.

2.1.C.2.c Child Care, Day Care Nursery: Provides non-home based care for any part of the day for five (5) or more children under the age of three (3).

2.1.C.2.d Child Care, Family Group Home: Provides home based care for maximum of twelve (12) preschool children plus five (5) children enrolled in a full day school program (or up to 17 children).

2.1.C.2.e Child Care, Family Home: Provides home based care for maximum of six (6) preschool children plus three (3) children enrolled in a full day school program (or up to 9 children).

2.1.C.2.f Child Care, Group Day Care Center: Provides non-home based group care for preschool and school-age children, whether or not the service is known as a day nursery, nursery school, kindergarten, cooperative, child development center, day care center, center for the developmentally disabled, progressive school, Montessori School, or by any other name.

2.1.C.2.g Child Care, Preschool Program: Provides non-home based care and a structured program for up to five (5) hours per day for children who are not attending a full day school program.

2.1.C.2.h Child Care, School-Age Program: Provides non-home based care for up to five (5) hours per school day, before or after, or, before and after regular school hours and all day during school holidays and vacations. This program is for children who are four (4) years eight (8) months

KR

**SECTION II
DEFINITIONS**

* **2.1.U.5 Use, Principal:** The main or primary purpose for which a structure or lot is designed, arranged, or intended, or for which it may be used, occupied or maintained under this Ordinance. Any other use within the main structure or use of any other structure or land on the same lot and incidental or supplementary to the principal use and permitted under this Ordinance shall be considered an accessory use.

2.1.U.6 Use, Substantially Different: A use which by reason of its normal operation would cause readily observable differences in patronage, service, appearance, noise, employment or similar characteristics from the use to which it is being compared.

2.1.V.1 Variance: Such departure from the terms of this Ordinance as the Board, upon appeal in specific cases, is empowered to authorize under the terms of Section XIV.

2.1.W.1 Wetland: Any area falling within the jurisdictional definitions of Section XII of this Ordinance.

2.1.Y.1 Yard: A portion of a lot upon which the principal building is situated, unobstructed artificially from the ground to the sky, except as otherwise provided herein. A court shall not be considered to be a yard or any part thereof.

2.1.Y.2 Yard, Front: A yard extending for the full width of the lot between the front line of the nearest building wall and the front lot line.

2.1.Y.3 Yard, Rear: A yard, except by an accessory structure or accessory use as herein permitted, extending for the full width of the lot between the rear line of the building wall and the rear lot line.

2.1.Y.4 Yard, Side: Yard extending for the full length of a building between the nearest building wall and the side lot line.

KK

SECTION III
ESTABLISHMENT OF DISTRICTS AND USES

centerline, or in the case of a curved centerline, at right angles to the tangent to the curve at the point of intersection.

3.4.6 When a lot is transected by a zoning district boundary, the regulations of this Zoning Ordinance applicable to the larger part by area of such lot may at the option of the owner be deemed to govern in the smaller part beyond such district boundary but only to an extent not more than forty (40) linear feet in depth beyond such district boundary.

3.4.7 In case of uncertainty, the Planning Board shall determine the exact location of the boundary.

3.5 DISTRICT PURPOSES The following purposes are hereby established for each of the districts:

3.5.1 Residential/Agricultural (R-4): The intent of this district is to provide for open space conservation, agricultural use, and predominantly very low density residential development on individual lots or in conservation subdivisions, which can be accommodated on the land without major disruptions of the natural terrain, vegetation, watercourses or surface drainage and which would not customarily have Precinct water and sewer systems.

3.5.2 Low Density Residential (R-3): The intent of this district is to provide for open space conservation, some agricultural use, and predominantly very low density residential development on individual lots or in conservation subdivisions which can be accommodated on the land without major disruptions of the natural terrain, vegetation, watercourses or surface drainage and which would not customarily have Precinct water and sewer systems.

3.5.3 Medium Density Residential (R-2): The intent of this district is to provide for open space conservation and predominantly medium density residential development on individual lots or in conservation subdivisions which can, because of the natural terrain, vegetation, watercourses or surface drainage, be permitted to occur at more intense levels of development and which may or may not have Precinct water and sewer service.

3.5.4 High Density Residential (R-1): The intent of this district is to provide for open space conservation and predominantly high density residential development on individual lots or in conservation subdivisions which can, because of the natural terrain, vegetation, watercourse or surface drainage or because of the availability of Precinct water and sewer service, be permitted to occur at more intense levels of development and which may have or be planned to have Precinct water and sewer service.

3.5.5 Commercial (B-1): The intent of this district is to provide limited commercial, institutional, professional and personal service uses along with residential uses.

* **3.5.6 Industrial (M-1):** The intent of this district is to provide areas for research and development, manufacturing, processing, assembly, wholesaling, and transportation-oriented activities and related services as trucking and warehousing provided that such uses are determined not to be injurious or hazardous to the public health, safety, and/or welfare.

3.5.7 Wetlands Conservation (overlay) (W-1): The intent of this overlay district is to provide protection for and appropriate use of lands as delineated in Section XII of this Ordinance.

KL

**SECTION III
ESTABLISHMENT OF DISTRICTS AND USES**

3.6 TABLE OF USES	R-4	R-3	R-2	R-1	B-1	M-1	VR-1	VB-1	VM-1	W-1
E. Institutional Uses/Community Facilities										
16. Town equipment garage, subject to Site Plan Review approval by the Planning Board.	S	S	S	X	X	P	X	X	X	
17. Essential Services as defined in paragraph 2.1.E.2.	P	P	P	P	P	P	P	P	P	
F. Commercial Uses										
* 1. Retail Establishment.	X	X	X	X	P	(S)	X	P	S	
* 2. Business Offices.	X	X	X	X	P	(P)	S	P	P	
3. Professional Offices.	X	X	X	S	P	P	S	P	P	
4. Banks and Lending Institutions.	X	X	X	X	P	X	X	P	X	
5. Restaurants.	X	X	X	X	P	S	X	P	S	
6. Drive-in Eating Establishments.	X	X	X	X	S	S	X	X	X	
7. Lounge	X	X	X	X	S	S	X	S	S	
8. Place of Entertainment in accordance with Section III, paragraph 3.7.9.	X	X	X	X	S	S	X	S	S	
9. Filling station, Service Station (with or without convenience store).	X	X	X	X	S	S	X	S	S	
10. Motor vehicle dealership, repair garage, body shop, paint shop.	X	X	X	X	S	S	X	X	S	
11. Veterinary hospital/kennel.	S	S	S	X	X	S	X	X	S	
12. Pet Grooming.	X	X	X	X	P	S	X	P	S	
13. Convenience store (without gas pumps).	X	X	X	S	P	S	X	P	S	
14. Airports, heliports, runways, control towers, administration buildings, hangers.	X	X	X	X	X	S	X	X	X	
15. Indoor motion picture establishment.	X	X	X	X	P	X	X	P	X	
16. Indoor and outdoor for profit recreation establishment or clubs.	X	X	X	X	S	S	X	S	S	
17. Funeral home or parlor.	X	X	S	S	S	X	S	S	X	
18. Beauty parlor, barber shop.	X	X	X	X	P	S	S	P	S	
19. Uses, Adult in accordance with Section III, paragraph 3.9.	X	X	X	X	S	X	X	S	X	
20. Self-Service Storage Facility.	X	X	X	X	S	S	X	X	S	
G. Industrial Uses										
1. Manufacturing, assembly, fabricating operations.	X	X	X	X	X	S	X	X	S	
2. Research and development corporate and business offices.	X	X	X	X	P	P	S	P	P	
3. Warehousing and wholesaling.	X	X	X	X	X	P	X	X	S	
4. Freight and trucking terminals.	X	X	X	X	X	S	X	X	X	
5. Bulk storage and distribution of goods, except fuels.	X	X	X	X	X	P	X	X	P	
6. Bulk storage of fossil fuels.	X	X	X	X	X	S	X	S	S	
7. Earth products removal subject to the provisions of Section XI.	S	S	X	X	X	S	X	X	X	

Section XII Wetlands Conservation District (Overlay)

KL

**SECTION III
ESTABLISHMENT OF DISTRICTS AND USES**

3.6 TABLE OF USES	R-4	R-3	R-2	R-1	B-1	M-1	VR-1	VB-1	VM-1	W-1
G. Industrial Uses										
8. Commercial sawmills.	X	X	X	X	X	S	X	X	S	
9. Junk yards, recycling centers.	X	X	X	X	X	X	X	X	X	
10. Laundry, dry cleaning plant.	X	X	X	X	S	P	X	S	P	
* 11. Closed storage of raw materials, finished goods or construction equipment.	X	X	X	X	S	(S)	X	X	S	
H. Accessory Uses										
1. Accessory bldgs., such as private garage, play-house, woodshed, green-house, tool shed, private swimming pool, or similar structures or additions thereto, normally associated with a residence or residential use, subject to provisions of Section IV.	P	P	P	P	P	P	P	P	P	
2. Accessory private garage for not more than three non-commercial motor vehicles and, except on a farm, not more than one half-ton rated or less in size commercial motor vehicles, subject to the provisions of Section IV.	P	P	P	P	P	S	P	P	S	
3. Accessory storage of trailer, unregistered automobile or boat provided: It shall either be stored within a principal or accessory building or not less than 25 feet from any front lot line and 10 feet from any side lot line, and it shall not be used for dwelling or sleeping purposes.	P	P	P	P	P	S	P	P	S	
4. Recreational Tenting and Recreational Camping Vehicles of a visitor in accordance with Section X, provided no residential tenting and recreational camping vehicles are located on the property for greater than 60 days per year.	P	P	P	P	P	S	P	P	S	
5. Accessory repair and storage facilities in any retail sales or consumer establishment provided: It shall not occupy more than 25 percent of the gross floor area.	X	X	X	X	P	X	X	P	X	

Section XII Wetlands Conservation District (Overlay)

KR

**SECTION III
ESTABLISHMENT OF DISTRICTS AND USES**

3.6 TABLE OF USES	R-4	R-3	R-2	R-1	B-1	M-1	VR-1	VB-1	VM-1	W-1
H. Accessory Uses										
* 6. Accessory building for storage or outside storage clearly necessary to the operation and conduct, of a permitted principal wholesale, transportation, industrial and/or commercial use.	X	X	X	X	S	S	X	S	S	
7. Newsstand, barbershop, dining room or cafeteria and similar accessory services primarily for occupants or users thereof within a hotel, office, industrial building, hospital or transportation terminal facility.	X	X	S	S	P	P	S	P	P	
8. Accessory off-street parking loading spaces as required in Section VI.	P	P	P	P	P	P	P	P	P	
9. Filling of water or wet area in accordance with Section XII.	S	S	S	S	S	S	S	S	S	
10. Seasonal greenhouse or farm stand selling goods primarily raised on the premises.	S	S	S	S	S	P	S	S	P	
11. Construction trailer(s) for a construction project provided a permit is secured from the Board of Selectmen under conditions they may prescribe.	P	P	P	P	P	P	P	P	P	
12. Temporary housing as a result of an emergency situation provided a permit is secured from the Board of Selectmen under condition they may prescribe.	P	P	P	P	P	P	P	P	P	
13. Childcare Family Home in accordance with Section III, paragraph 3.7.7.	P	P	P	P	P	P	S	S	S	
14. Childcare Family Group Home in accordance with Section III, paragraph 3.7.7.	S	S	S	S	S	S	S	S	S	
15. Small Wind Energy Systems in accordance with Section III, paragraph 3.11.	P	P	P	P	P	P	P	P	P	
16. Home Business in accordance with Section III, paragraph 3.7.3, except for the VB-1 and VM-1 districts. Site Plan Review required in all districts.	S	S	S	S	S	S	S	P	P	

Section XII Wetlands Conservation District (Overlay)

KL

**SECTION IV
DIMENSIONAL AND DENSITY REQUIREMENTS**

- (f) 15,000 sq. ft. + 2,000 sq. ft. for each dwelling unit more than one on a lot.
- (g) The minimum lot width at the front yard setback line shall not be less than 85 percent of the minimum lot frontage required for the District. The frontage on a road at a cul-de-sac may be less than specified if the lot width at the depth of the front yard setback line meets the minimum lot frontage requirements, but in no event less than 30 feet.
- (h) For residential use only in the M-1 zone the sideline setback shall be 30 feet.
- (i) The required square footage of land area for the first dwelling unit shall be equal to the minimum lot area as defined in the Table of Dimensional Requirements. For each additional dwelling unit an additional 2,000 square feet of land area shall be required.
- (j) When the footnoted commercial or industrial uses abut residential uses or a residential district or are situated in a residential area, the minimum front setback shall be 25 feet and the minimum side setback shall be 25 feet from a property line abutting a residential use or district.
- (k) In the B-1 and M-1 zones, the maximum gross floor area of commercial retail stores and restaurants shall not exceed 40,000 square feet.
- (l) In the VB-1 and VM-1 zones, the maximum gross floor area of commercial retail stores and restaurants shall not exceed 20,000 square feet.

4.4 SPECIAL DIMENSIONAL AND DENSITY CONDITIONS The following special conditions shall apply as appropriate to this Section of this Ordinance.

4.4.1 Detached Accessory Building: In all districts, a detached accessory building shall conform to the following provisions:

- (a) It shall not be less than the front setback for the district or less than 10 feet from any other lot line or from any principal or accessory building.
- (b) It shall not exceed 20 feet in height unless the accessory is placed to comply with principal building setback in which case it will conform to the height restriction of the district.

4.4.2 Attached Accessory Building: In all districts, an accessory building attached to the principal building shall be considered as an integral part therefore and shall be subject to front, side, and rear yard requirements applicable to the principal building.

✱ **4.4.3 Principal Structure:** Except for municipal facilities and public utilities, only one principal structure/principal use shall be permitted on a lot, except as noted in 8.6.5. In the B-1 and M-1 zones, there may be multiple principal nonresidential structures and uses within structures so long as each use is listed as a permitted (P) use or use permitted by special exception (S) in 3.6 TABLE OF USES. In the B-1 and M-1 zones, the maximum gross floor area of commercial retail stores and restaurants shall not exceed 40,000 square feet. In the VB-1 and VM-1 zones, the maximum gross floor area of commercial retail stores and restaurants shall not exceed 20,000 square feet. In the VB-1 and VM-1 zones, there may be multiple principle structures and uses within structures so long as each use is listed as a permitted (P) use or use permitted by special exception (S) in 3.6 TABLE OF USES. Nothing herein shall be construed



Thorne Property

Hopkinton, NH

1 inch = 500 Feet



March 20, 2018



www.cai-tech.com

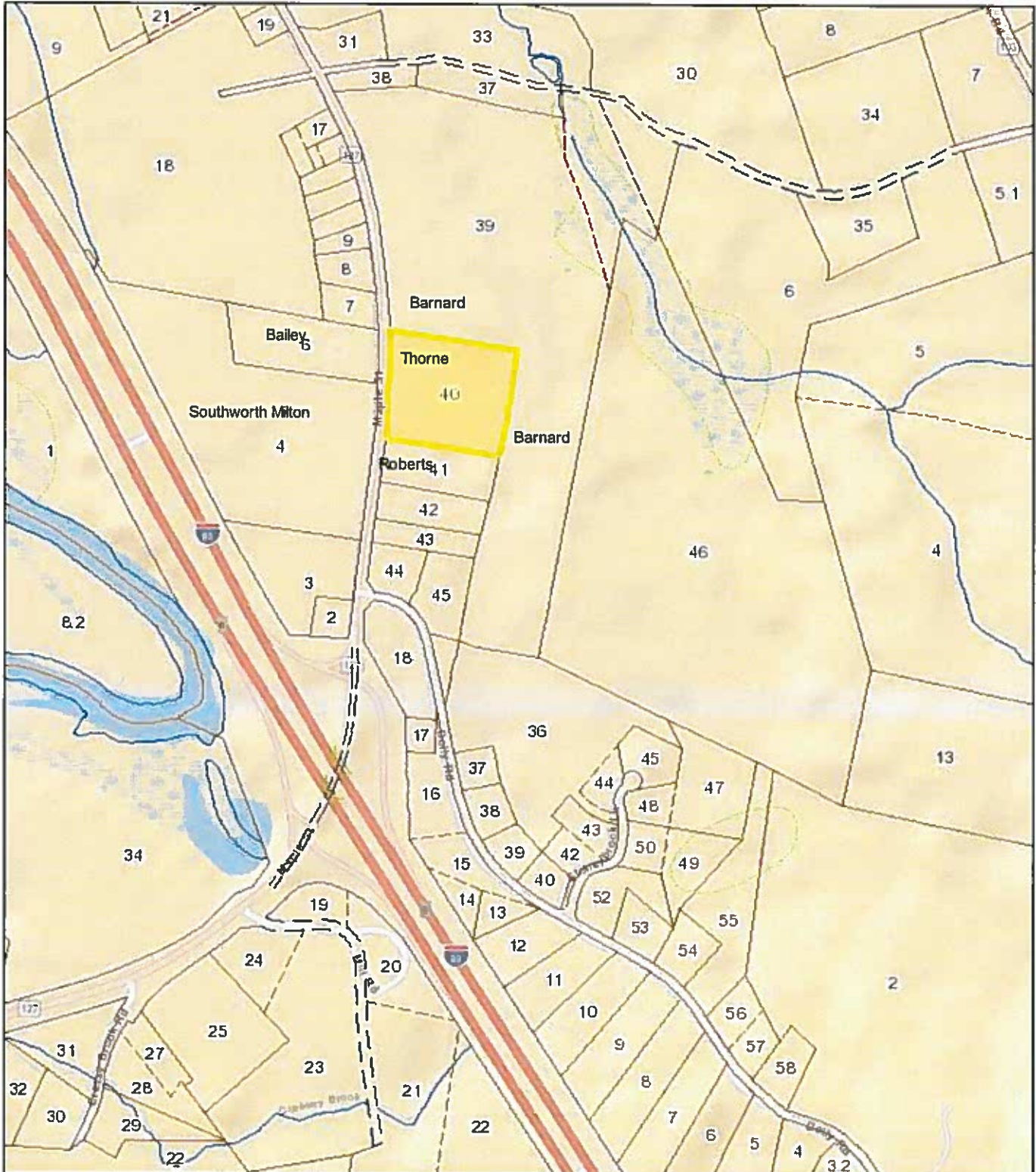

Data shown on this map is provided for planning and informational purposes only. The municipality and CAI Technologies are not responsible for any use for other purposes or misuse or misrepresentation of this map.

#2018-06

**TOWN OF HOPKINTON, NH
APPLICATION TO PLANNING BOARD**

List of Abutters					
Map	Lot(s)	Property Owner(s) Name	Mailing Address	Office Use Only	
227	4	Southworth-Milton, Inc.	100 Quarry Drive Milford, MA 01757		
227	6	Brenda J. Bailey	512 Maple Street Contoocook, N.H. 03229		
227	39	Helen L. Barnard Revocable Trust c/o Robert W. Barnard	3675 Amberly Circle, Unit C301 Naples, FL 34112		
227	41	Virginia & Woodbury Roberts c/o Woodbury Roberts	575 Maple Street Contoocook, N.H. 03229		
Professionals					
Owner		Lisa Thorne	519 Maple Street Contoocook, N.H. 03229		
Applicant		Summit Holdings LLC	43 Bear Hill Road Washington, N.H. 03280		
Engineer		Anthony Costello A.C. Engineering & Consulting	43 Bear Hill Road Washington, N.H. 03280		

→ Anthony Costello
David Barkie

2

Name and Address of Sender
 Town of Hopkinton
 330 Main Street
 Hopkinton, NH 03229
 Re: 04/03/2018 zba

Check type of mail or service:
 Adult Signature Required
 Certified Mail
 COD
 Delivery Confirmation
 Express Mail
 Insured
 Adult Signature Restricted Delivery
 Recorded Delivery (International)
 Registered
 Return Receipt for Merchandise
 Signature Confirmation

Affix Stamp Here
 (If issued as a certificate of mailing or for additional copies of this bill)
 Postmark and Date of Receipt

Article Number	Addressee (Name, Street, City, State, & ZIP Code™)	Postage	Fee	Handling Charge	Actual Value Registered	Insured Value	Due Sender if GDB	ASR Fee	ASRD Fee	DC Fee	SC Fee	SH Fee	RD Fee	RR Fee
1. 70161370000240211047	Lisa Thome 519 Maple St. Contoocook, NH 03229	.47	3.45											
2. 70161370000240211054	Southworth Milton Inc 100 Quarry Dr Milford, MA 01757	.47	3.45											
3. 70161370000240211061	Brenda J. Bailey 512 Maple St Contoocook, NH 03229	.4	3.45											
4. 70161370000240211078	Helen L. Barnard Rev. Trust c/o Robert W. Barnard 3675 Amberly Cir, Unit C301 Naples, FL 34112	.47	3.45											
5. 70161370000240211085	Virginia & Woodbury L. Roberts c/o Woodbury C. Roberts 63 Gage Hill Rd Hopkinton, NH 03229	.47	3.45											
6. 70161370000240211092	Anthony Costello A.C. Engineering & Consulting 43 Bear Hill Rd Washington, NH 03280	.47	3.45											
7. 70161370000240211108	Summit Holdings LLC 43 Bear Hill Rd Washington, NH 03280	.47	3.45											
8. 70161370000240211115	Peter Grenier River House Properties LLC 1 Hardy Rd Bedford, NH 03110	.47	3.45											
Total Number of Pieces Listed by Sender		8												
Total Number of Pieces Received at Post Office		8												

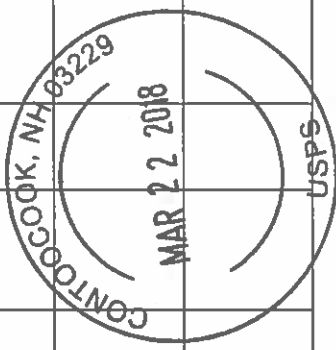

See Privacy Act Statement on Reverse

Complete by Typewriter, Ink, or Ball Point Pen

22

Name and Address of Sender	Article Number	Check type of mail or service: <input type="checkbox"/> Adult Signature Required <input checked="" type="checkbox"/> Certified Mail <input type="checkbox"/> COD <input type="checkbox"/> Delivery Confirmation <input type="checkbox"/> Express Mail <input type="checkbox"/> Insured <input type="checkbox"/> Adult Signature Restricted Delivery <input type="checkbox"/> Recorded Delivery (International) <input type="checkbox"/> Registered <input type="checkbox"/> Return Receipt for Merchandise <input type="checkbox"/> Signature Confirmation	Postage	Affix Stamp Here (If issued as a certificate of mailing or for additional copies of this bill) Postmark and Date of Receipt	ASR Fee	ASRD Fee	DC Fee	SC Fee	SH Fee	RD Fee	RR Fee	
												Actual Value Registered
Town of Hopkinton 330 Main Street Hopkinton, NH 03229 Re: 05/01/2018 zba												
1. 70161370000240211313		Summit Holdings, LLC 43 Bear Hill Road Washington, NH 03280	.47	3.45								
2. 70161370000240211320		Lisa Thome 519 Maple Street Contoocook, NH 03229	.47	3.45								
3. 70161370000240211337		A.C. Engineering & Consulting 43 Bear Hill Road Washington, NH 03280	.4	3.45								
4. 70161370000240211344		Southworth-Milton Inc. 100 Quarry Drive Milford, MA 01757	.47	3.45								
5. 70161370000240211351		Brenda J. Bailey 512 Maple Street Contoocook, NH 03229	.47	3.45								
6. 70161370000240211368		Helen L. Barnard Rev. Trust c/o Robt. Barnard 3675 Amberly Cir., Unit C301 Naples, FL 34112	.47	3.45								
7. 70161370000240211375		Virginia & Woodbury L. Roberts c/o Woodbury C. Roberts 63 Gage Hill Rd Hopkinton, NH 03229	.47	3.45								
8.												

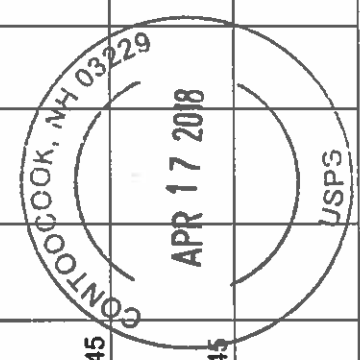

Total Number of Pieces Listed by Sender	7
Total Number of Pieces Received at Post Office	7
Postmaster, Per (Name of receiving employee) <i>[Signature]</i>	

See Privacy Act Statement on Reverse

Complete by Typewriter, Ink, or Ball Point Pen

ent:	1007884	TOWN OF HOPKINTON	Phone:	(603) 746-3170
#	796150	Requested By:	Fax:	
les Rep.:	LEGA	CATHY VALLEY	Phone:	(603) 369-3210
		cathy@cmonitor.com	Fax:	(603) 228-8238
ass.:	C166	LEGALS		
art Date:	04/20/2018	End Date:	04/20/2018	Nb. of Inserts: 2
ublications:	CONCORD MONITOR, MONITOR ONLINE			
tal Price:	\$114.60		Page 1 of 1	

+ PUBLIC NOTICE +

**HOPKINTON ZONING BOARD OF ADJUSTMENT
MAY 1, 2018**

Notice is hereby given that the Hopkinton Zoning Board of Adjustment will meet on Tuesday, May 1, 2018 at 5:30 PM in the Hopkinton Town Hall, 330 Main Street Hopkinton, to review and take action on the following: **Peter Grenier (#2018-05)** Variance for multi-family dwelling units on property owned by River House Properties, LLC at 1966 Maple Street in the M-1 (Industrial) district, TM/L 210-018-000. The application was submitted in accordance with Zoning Ordinance Table of Uses 3.6.A.3. **Summit Holdings, LLC (#2018-06)** Special Exceptions for retail, closed storage and associated outside storage on property owned by Lisa Thorne on Maple Street in the M-1 (Industrial) district, TM/L 227-040-001. The application was submitted in accordance with Zoning Ordinance Table of Uses 3.6.F.1, 3.6.G.11 and 3.6.H.6.

+ April 20 +

7016 1370 0002 4021 1412

U.S. Postal Service™
CERTIFIED MAIL® RECEIPT
Domestic Mail Only

For delivery information, visit our website at www.usps.com™

OFFICIAL USE

Certified Mail Fee
\$ 3.45

Extra Services & Fees (check box, add fee as appropriate)

Return Receipt (hardcopy) \$

Return Receipt (electronic) \$

Certified Mail Restricted Delivery \$

Adult Signature Required \$

Adult Signature Restricted Delivery \$



Postage
\$.47

Total Postage and Fees
\$ 3.92

Sent To
Lisa Thorne
Street and Apt. No., or PO Box No.
519 Maple St.
City, State, ZIP+4
Centoocook NH 03229

PS Form 3800, April 2015 PSN 7530-02-000-9047 See Reverse for Instructions

7016 1370 0002 4021 1405

U.S. Postal Service™
CERTIFIED MAIL® RECEIPT
Domestic Mail Only

For delivery information, visit our website at www.usps.com™

OFFICIAL USE

Certified Mail Fee
\$ 3.45

Extra Services & Fees (check box, add fee as appropriate)

Return Receipt (hardcopy) \$

Return Receipt (electronic) \$

Certified Mail Restricted Delivery \$

Adult Signature Required \$

Adult Signature Restricted Delivery \$



Postage
\$.47

Total Postage and Fees
\$ 3.92

Sent To
Summit Holdings LLC
Street and Apt. No., or PO Box No.
43 Bear Hill Rd
City, State, ZIP+4
Washington NH 03280

PS Form 3800, April 2015 PSN 7530-02-000-9047 See Reverse for Instructions

**Lisa A. Thorne
519 Maple Street
Hopkinton, NH 03229
lisathorne64@gmail.com
603-491-5624**

March 19, 2018

To whom it may concern:

I, Lisa Thorne, owner of 519 Maple Street, Hopkinton, NH, hereby authorize Summit Holdings, LLC, (David Barkie and Anthony Costello) to act on my behalf at the April, 2018 Zoning Board of Adjustment Meeting for the Town of Hopkinton, NH .

Thank you

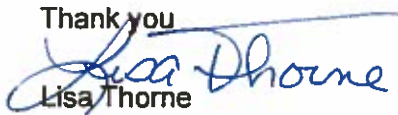
Lisa Thorne

MERRIMACK COUNTY RECORDS *Kathi L. Guay*, CPO, Register

Return to: Lisa A. Thorne

1449
2-
25-

519 Maple St.

Hopkinton, NH 03229

QUITCLAIM DEED

KNOW ALL MEN BY THESE PRESENTS, That We, Thomas K. Thorne, married, of 189 Carter Hill Road, Concord, NH 03303 and Lisa A. Thorne, Married, of 519 Maple Street, Hopkinton, NH 03229, for consideration paid, grant to Lisa A. Thorne, Married, of 519 Maple Street, Hopkinton, NH 03229, with QUITCLAIM covenants,

A certain tract or parcel of land, with the improvements thereon, in the Town of HOPKINTON, County of MERRIMACK, and State of New Hampshire, bounded and described as follows:

Beginning at the east side of the highway known as Highway 127 at the northeast corner of these granted premises;

Thence in a general easterly direction along a stone wall about thirty-seven (37) rods to an iron pin at the end of the wall;

Thence in a general southerly direction along a wire fence about thirty-four (34) rods to an iron post;

Thence in a general westerly line along a fence about thirty-seven (37) rods to an iron pin at the end of a stone wall at the highway;

Thence in a general northerly direction along the stone wall on the easterly side of the highway about thirty-four (34) rods to the point begun at.

Meaning and Intending to describe and convey the same premises conveyed to Thomas K. Thorne and Lisa A. Thorne by deed dated October 8, 2010 and recorded at Book 3219, Page 195 of the Merrimack County Registry of Deed.

This conveyance is made pursuant to the Final Decree of Divorce in the matter of Lisa A. Thorne and Thomas K. Thorne, 6th Circuit Court, Concord Family Division, Case Number 629-2013-DM-00469, dated April 18, 2014, and is exempt from transfer tax pursuant to New Hampshire RSA 78-B:2, XIII.

I, Thomas K. Thorne, ^{spouse of Lisa A. Thorne} hereby release to said Grantee all rights of homestead and all other interests therein. LT

Signed May, 20, 2014

Thomas K. Thorne

Thomas K. Thorne

Signed May, 22, 2014

Lisa A. Thorne

Lisa A. Thorne

STATE OF NEW HAMPSHIRE
MERRIMACK, SS.

This instrument was acknowledged before me on May, 20, 2014, by Thomas K. Thorne.

[Signature]

Notary Public / Justice of the Peace
My Commission Expires: August 23, 2016

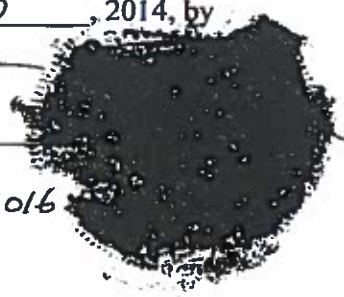

STATE OF NEW HAMPSHIRE
MERRIMACK, SS.

This instrument was acknowledged before me on May, 22, 2014, by Lisa A. Thorne.

[Signature]

Notary Public / Justice of the Peace
My Commission Expires:





Town of Hopkinton

130 Main Street • Hopkinton, New Hampshire 03229 • www.hopkinton-nh.gov
Tel: 603-746-3170 Fax: 603-746-3049

HOPKINTON PLANNING BOARD MINUTES

* JANUARY 9, 2018

Members present: Chairman Bruce Ellsworth, Vice Chairman Michael Wilkey, Ex-Officio Jim O'Brien, Rich Steele, and Alternates Jim Fredyma and Clarke Kidder. Absent: Cettie Connolly, Jane Bradstreet, Celeste Hemingson and Alternate Timothy Britain. Staff present: Planning Director Karen Robertson.

I. **Call to Order.** Chairman Ellsworth called the meeting to order at 6:30 PM in the Hopkinton Town Hall. Due to the absence of regular members, Mr. Fredyma and Mr. Kidder were designated as voting members.

II. **Review of the Minutes of December 12, 2017.**

Clarke Kidder, seconded by Jim Fredyma, moved to **APPROVE** the Minutes of December 12, 2017 as presented. Motion carried unanimously in favor (Kidder, Steele, O'Brien, Fredyma, Wilkey, and Ellsworth). Vote: 6-0-0

Jim O'Brien, seconded by Michael Wilkey, moved to **APPROVE** the Notice of Decision of December 12, 2017 as presented. Motion carried unanimously in favor (Kidder, Steele, O'Brien, Fredyma, Wilkey, and Ellsworth). Vote: 6-0-0

III. **Conceptual Consultations.** There were no conceptual consultations.

IV. **Applications.**

* **Subdivision (#2018-1)**, Application of Dave Barkie for a 2-lot subdivision of property owned by Lisa Thorne, located at 519 Maple Street, Tax Map 227, Lot 40, M-1 District.

Engineer Anthony Costello addressed the Board presenting a plan of the 2-lot subdivision. The property consists of 7.7 acres of which 1.5 acres is wetland. The proposal is to create one new lot that will be used for commercial/industrial purposes. The new lot is shown as Lot 40.1 and consists of 3.70 acres with 266.3 feet of frontage. The remaining lot will include the existing residence and consist of 4.04 acres with 256.81 feet of frontage.

Currently, it is their intentions to construct a 5-bay metal framed building with offices in the front portion. One bay will be used for Mr. Barkie's landscaping business. It is anticipated that the remaining space will be available for rent. The proposal will require a Special Exception from the Zoning Board of Adjustment and Site Plan Review by the Planning Board.

The Board briefly discussed Mrs. Robertson's review comments, agreeing that any approval may be conditional.

Jim O'Brien, seconded by Jim Fredyma, moved to **ACCEPT** Application #2018-1 as complete and for consideration. Motion carried unanimously in favor (Kidder, Steele, O'Brien, Fredyma, Wilkey, and Ellsworth). Vote: 6-0-0

Chairman Ellsworth opened the public hearing portion of the meeting.

Abutter Woody Roberts addressed the Board explaining that his family owns the abutting property. While he currently has no objections to the proposal, he is interested in the future use of the property. He further noted that there is a well-established buffer of trees along the property line.

There being no further public testimony, the public hearing portion of the meeting was closed.

Michael Wilkey, seconded by Clarke Kidder, moved to **APPROVE** Application #2018-1 with the following conditions:

- 1) Final plans shall include the right-of-way width of Maple Street, the location of the existing well and utilities, and shall be signed and sealed by the appropriate professionals.
- 2) Submittal of NH DES State Subdivision Approval.

Motion carried unanimously in favor (Kidder, Steele, O'Brien, Fredyma, Wilkey, and Ellsworth). Vote: 6-0-0

Mr. Kidder noted for the record that the only action taken by the Planning Board was to approve the proposed subdivision.

V. Other Business.

During a recent Select Board meeting, Tom Komisarek expressed interest in constructing a residence on his property that is located along Buzzwell Corner Road, which is a Class VI road. RSA 674:41 requires review and comments by the Planning Board, prior to the Select Board taking action on such a request.

Mr. O'Brien stated that the Select Board is interested in moving forward and have had discussions concerning the matter of long-term maintenance of the Class VI road. As a result, Mr. Komarisarek will be working with the Town Administrator on a draft formal agreement that will require Mr. Komisarek to maintain the road to his residence.

At this time, Mr. Komisarek addressed the Planning Board to explain his proposal to construct a residence. He noted that there are three other residences along the Class VI road that were constructed prior to the change in classification.

Chairman Ellsworth questioned whether the owners of the three residences currently have agreements with respect to maintenance of the road. In response, Mr. O'Brien stated that he was not aware of an agreement. Mr. Komisarek noted that the owners of the residences maintain the road and he plows the road.

